

Carrucola doppia in linea concepita specificatamente per l'uso su teleferiche. Movimento su cuscinetti a sfere sigillati, per basso attrito ed alta velocità (20 m/s max). Struttura in lega d'alluminio e ruote in acciaio inox. Utilizzabile con corde di diametro fino a 13 mm e cavo metallico fino a 12 mm. Dotata di ampio foro di attacco principale e punto di connessione secondario superiore.

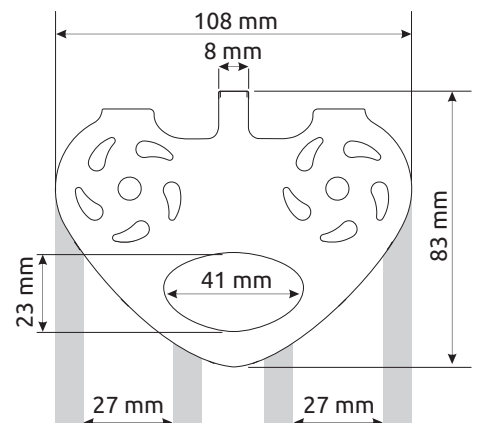

MBL 20 kN WLL 10 kN



Art.	Descrizione articolo	Peso	Diametro carrucola	Diametro corda	Diametro cavo	Carico lavoro Max	Carico di rottura	CE EN 12278
		g	mm	Max - mm	Max - mm	kN	kN	
3121	FLYTE	280	27	13	12	10	20	•

